

Love how you work.®

Steelcase

Visit steelcase.com

Europe & Africa Espace Européen de l'Entreprise 1, allée d'Oslo BP 40033 Schiltigheim 67012 Strasbourg Cedex France
tel: +33 3 88 13 30 30 fax: +33 3 88 28 31 78

North America 901, 44th Street Grand Rapids MI 49508 USA
tel: +1 616 247 27 10 fax: +1 616 246 40 40

Asia Pacific & India 4th floor, N32 Kowa Bldg 5-2-32 Minami-Azabu Minato-Ku Tokyo 106-0047 Japan
tel: +81 3 3448 9611 fax: +81 3 3448 9617

Latin America 901, 44th Street Grand Rapids MI 49508 USA
tel: +1 616 247 27 10 fax: +1 616 246 40 40

Middle East Design House unit A2 PO Box 502596 Dubai Media City Dubai UAE
tel: +971 4 369 7838 fax: +971 4 369 7837

Product design Activa: Stefan Brodbeck – www.brodbeckdesign.de **Product design Activa Lift 2:** Steelcase Design
Product design Parito, Kalidro & FrameOne: Stefan Brodbeck – www.brodbeckdesign.de **Product design Think:** Glen Oliver Löw
Product design Please task chair: r/p/k industrial design **Product design Amia:** Steelcase Design in collaboration with IDEO

DM699EN 11/10 © 2010 Steelcase® All rights reserved. All specifications subject to change without notice.
Printed on at least 60% recycled paper. Cert no. BV-COC-858659. Printed in France by OTT Imprimeurs – Wasselonne.



Activa / Activa Lift 2 Business is moving faster

Steelcase



Activa / Activa Lift 2 Business is moving faster

With its innovative products and space solutions, Steelcase enables its customers throughout the world to set free the latent potential within the company and its people. This successful activation of the workspace is based on **intensive research and user observation**. We developed the Activa desk system in response to user and company requirements.

From **assembly within seconds** to the **height adjustment with no tools** – the technical details of Activa are a real payoff in the hectic reality of every-day office life. Thanks to its modular construction, assembly and reconfiguration costs can be drastically reduced. The Activa and Activa Lift 2 desk family with in total seven versions in a single design provides a made to measure, **ergonomic** solution for every requirement and **professional cable management** at the workplace.





Activa and Activa Lift 2 Truly flexible

Clear lines. Activa and Activa Lift 2 combine attractive design with uncompromising quality. The solid steel and aluminium structure makes Activa a reliable partner.



1 becomes 2. Whether as a single workstation or set out in multiples, with Activa, the use of partitions is simplicity itself. No compromise in height adjustment and desk organisation.

Individual side panels
Three standard finishes are available: Beech Brown, mirror-finish Smokey Grey and undulated aluminium.



Activa Lift 2. Quiet-running motor operated desk, adjustable from 650 to 1300mm, including control unit, memory function (optional).



Activa

Activa embodies all the experience of our engineers, the Steelcase know-how and, especially important, the feedback from many users. The result is a desk system that sets new standards. With a variety of desktop shapes, linking possibilities and add-ons, Activa can be ideally adapted to your real needs. Whether you work alone or in a team...



H620 - 900

Activa Telescopic
Can be quickly set to different heights – no tools required.



H720

Activa Standard
The low-cost entry level version.



H620 - 900

Activa Crank
The ideal desk-sharing partner.



Activa Lift 2

Sit/Stand workstation. A family that, with its four height versions, talks the language of design! Highly dynamic: healthy working with active alternation of standing and seated postures with the Lift Desk. Activa Lift 2 is rigid, so there is no need for an horizontal stabilisation bar.

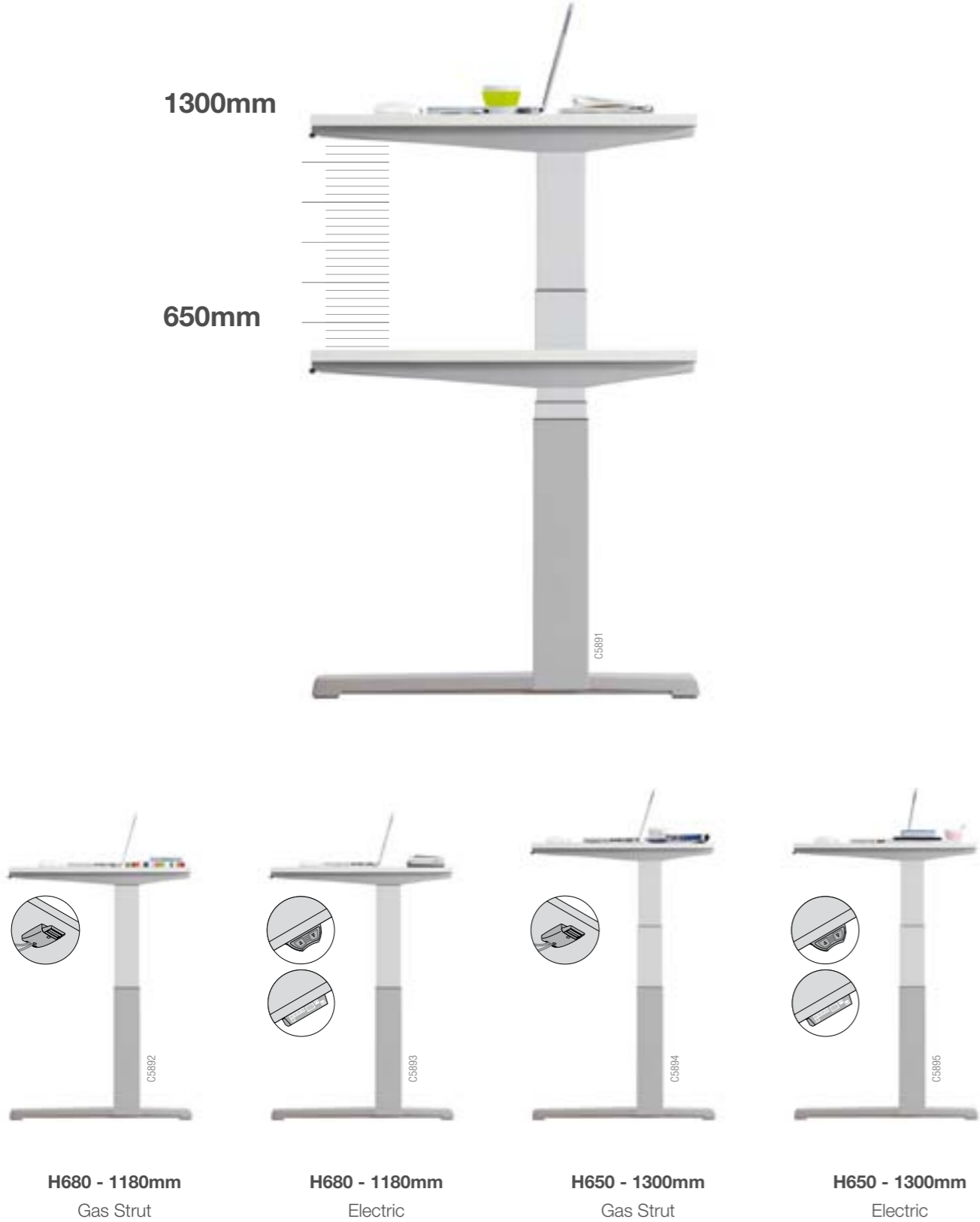

Activa Assembled in seconds

Activa was designed for fast reactions. Installation, removal or reconfiguration: we have never assembled a desk so fast and so easily. All that you need is one person, an Allen key and 30 seconds.



Discover the design details of Activa. From the steely sturdiness of the side frames, the precision mortise and tenon jointing of the cross-bar to the sliding top guides, Activa is a technical show-piece.



15 sec

In 15 seconds, you have fitted together the cross-bar and the two fully pre-assembled side frames of the desk base.



20 sec

Next: slide in the worktop, push it onto the side frames and lock it in place.



30 sec

Now just fix the cross-bar with four Allen screws and your Activa workplace is ready for use!



Activa Cable management in record time

Activa hides cables from sight. Convenient and intelligent - horizontal cable ducts and risers can be mounted and accessed without tools. They are extremely roomy and can be lowered by full 260mm - that makes the cabling of the Activa Lift 2 version easy to carry out. The rigid, telescopic and crank-adjusted desk versions are fitted with a sliding top. With Activa, cable management is child's play.



Telescopic cable riser
Activa



Telescopic cable riser
with open cover
Activa



Cable carrier
Activa Lift 2



Flexible riser section
Activa and Activa Lift 2



Sliding top
Activa



Cable duct (horizontal)
Activa and Activa Lift 2



Cable management
Activa and Activa Lift 2



Cable riser
Activa and Activa Lift 2



Also available: the Activa's cable riser. Fitted without tools, it is telescopic and can be installed on the fixed, telescopic and crank-adjusted versions. The cover is easily removed and gives access at any time to the height adjustment of the telescopic desk – without tools.

Activa and Activa Lift 2 Details

Accessories to equip your workplace. Parts can be added to Activa and Activa Lift 2 like a construction kit – Orga-Rail for top organisation, holding a multitude of useful aids ready to hand, adapters for technical accessories and cable control at the desk and to the power source.



Modesty panel



Top extension



1+1 Organisation accessories



Partito Rail



Orga-Rail



Technical equipment

Intelligent design details. Many can be made use of without tools, such as the telescopic height adjustment, the cable riser or the Activa's CPU holder. A workplace designed down to the last detail and guaranteed a pleasure to use.



CPU holder, no tools required, inside or outside mounted
Activa



CPU holder, inside mounted, no tools required
Activa Lift 2



Leveling glides to compensate uneven floors, adjustment range $\pm 15\text{mm}$



Telescopic height adjustment, no tools required



Activa System

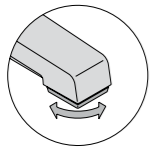
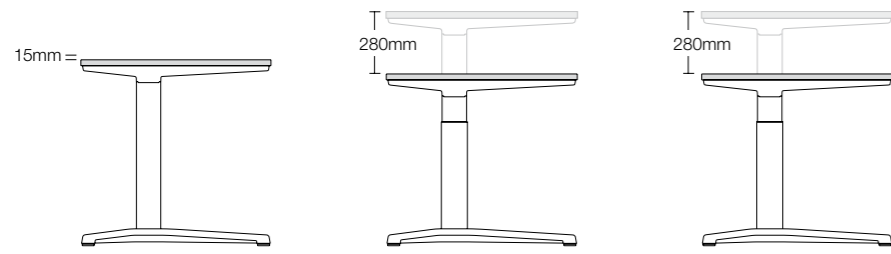

H720mm

Activa Standard
Foot adjustment 15mm

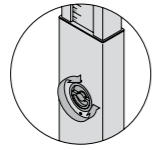

H620 - 900mm

Activa Telescopic
No tools required
Foot adjustment 15mm

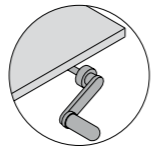

H620 - 900mm

Activa Crank
Crank operated
Foot adjustment 15mm

Activa with a single design principle for all height adjustment versions.

In one area, you can perfectly combine different versions.

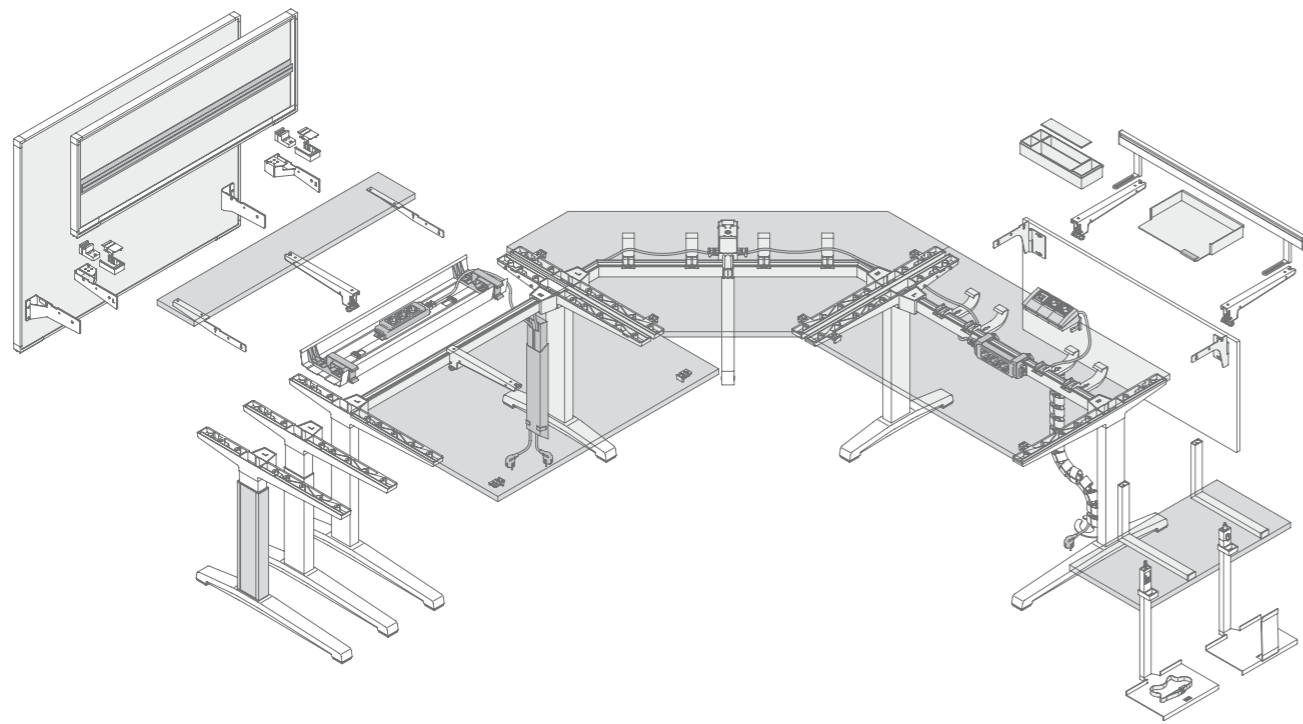

Activa has system. Activa provides a host of modular elements with which you can set up your workplace exactly as you need it. Your workplace made-to-measure.

Activa Top overview 1:100

Tops

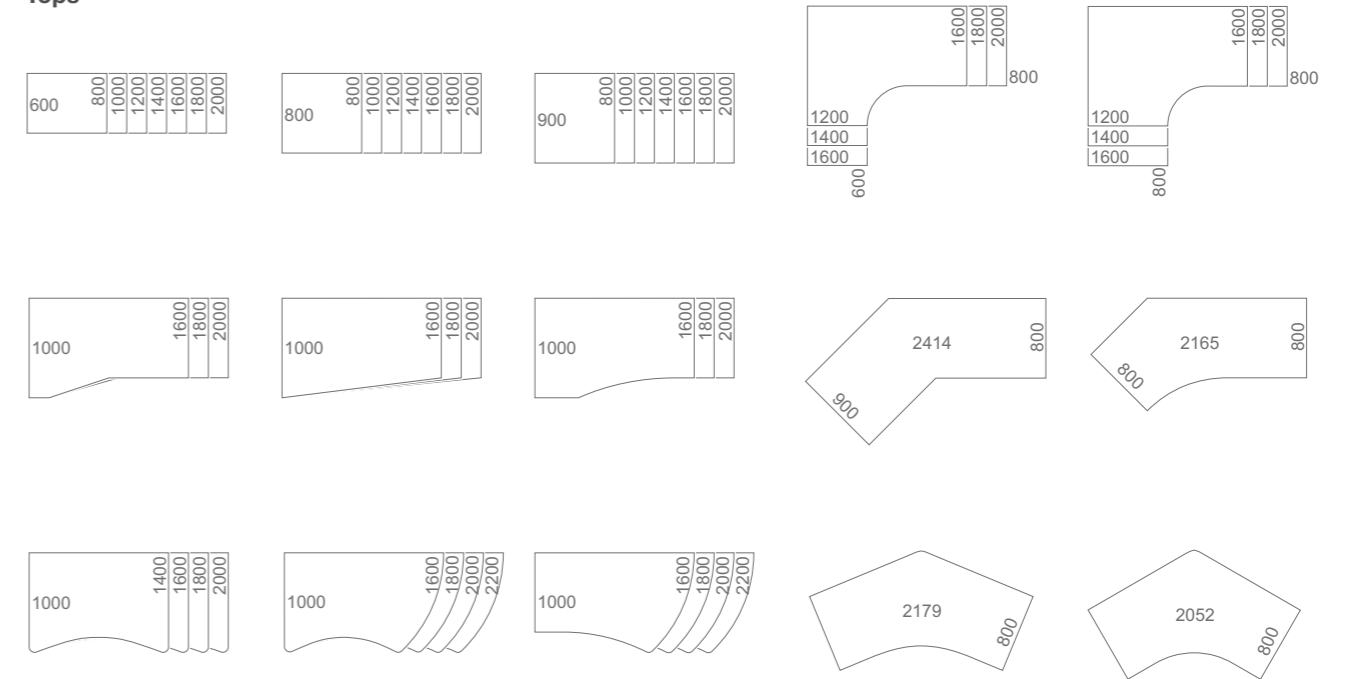

Extensions

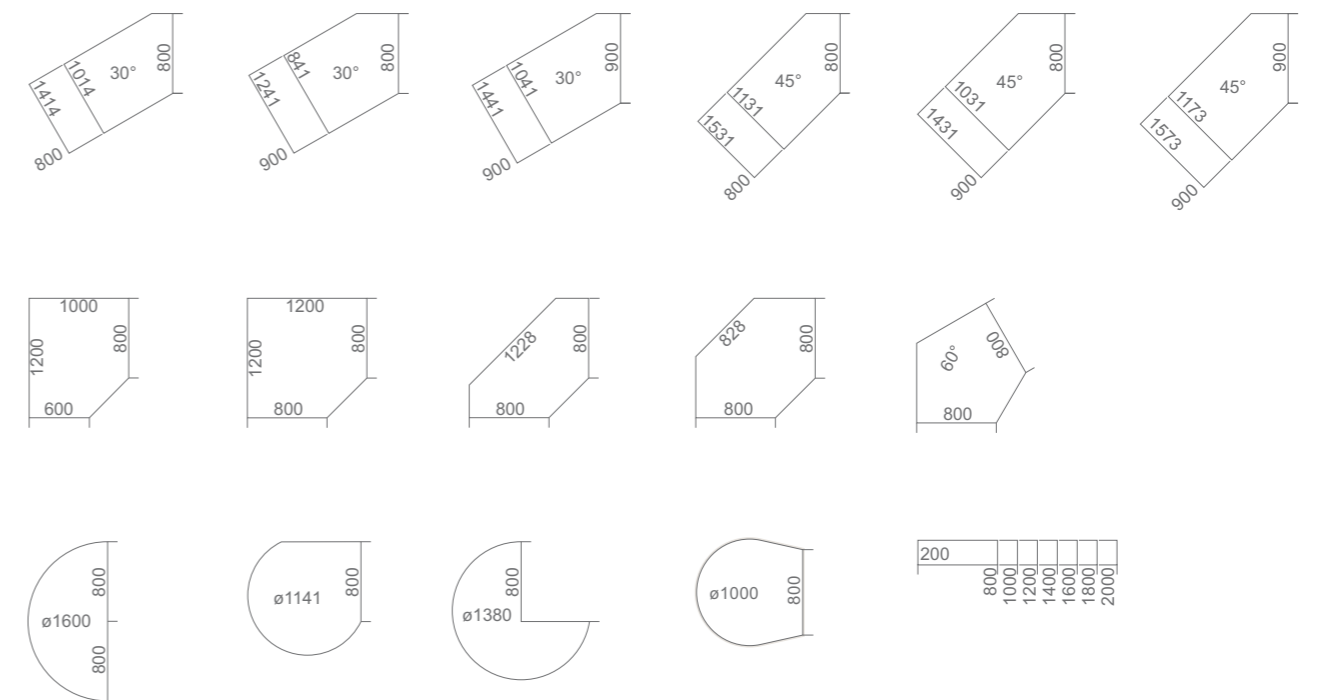

Activa Lift 2 System

Electric tables

650-1300mm

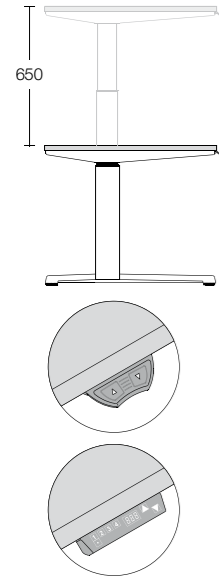

680-1180mm

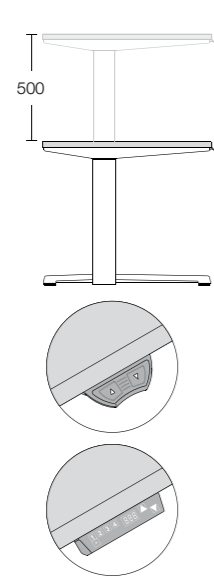

Gas strut tables

650-1300mm

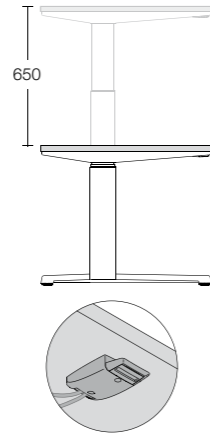

680-1180mm

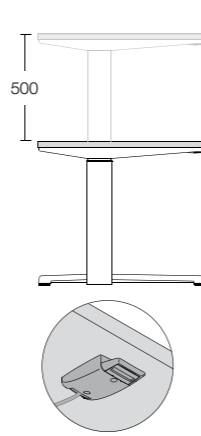

Electric tables

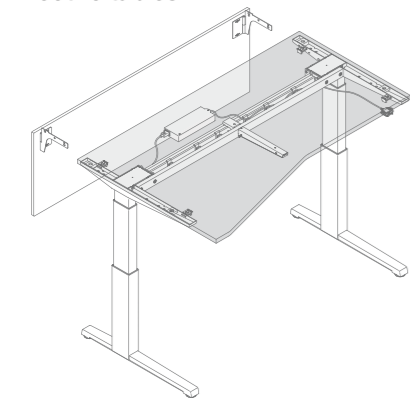

H650 - 1300mm

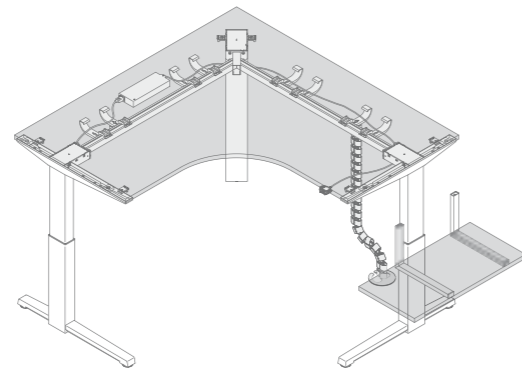

H680 - 1180mm

Gas strut tables

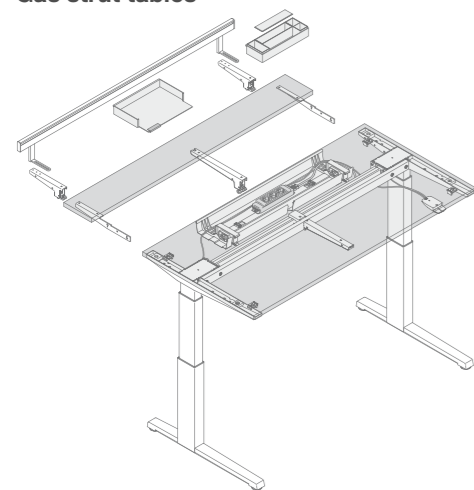

H650 - 1300mm

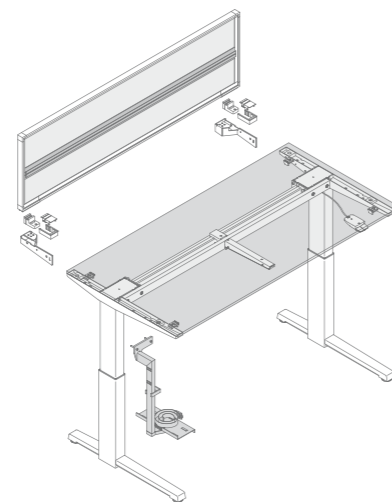

H680 - 1180mm

Activa Lift 2 Top overview 1:100

Electric tables

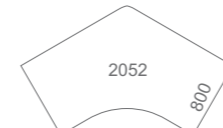
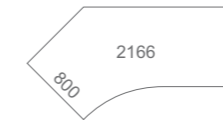
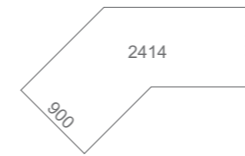
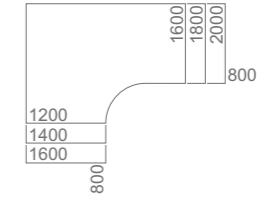
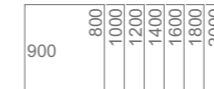

Gas strut tables

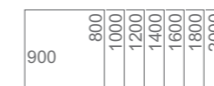
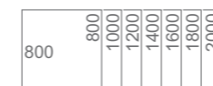

Finishes



Activa Design Kit
(Not available for Activa Lift 2)



Top: Snow W4
Base: Silver
Panel: Undulated aluminium W20



Top: Snow W4
Base: Graphite 210
Panel: Smokey Grey 360



Top: Beech Brown (TechTop) B4
Base: Pearl Snow ZW
Panel: Undulated aluminium W20



Top: Beech Brown (TechTop) B4
Base: Silver SL
Panel: Smokey Grey 360



Top: Beech Brown (TechTop) B4
Base: Graphite 210
Panel: Undulated aluminium W20



Top: Light Oak F3
Base: Pearl Snow
Panel: Smokey Grey 360



Top: Light Oak F3
Base: Silver
Panel: Undulated aluminium W20



Top: Light Oak F3
Base: Silver
Panel: Graphite 210

Activa Environmental performance

Since 1912, Steelcase has been committed to continually reducing the environmental impacts of its products and activities on a global scale, by constantly seeking more effective ways to conserve resources, prevent pollution and nurture environmental consciousness in its people every day.

During Activa's development process we evaluated the environmental aspects of the products at each stage of its life cycle: materials extraction, production, transport, use and reuse, until the end of its life.

End of life

Activa is 99% recyclable by weight (packaging materials are 100% recyclable).

Plastic parts are clearly marked for easy sorting and effective recycling.

After delivery of the desks, about 40% of the EPP edge protections are returned to Steelcase and directly reused for other desks.

Use

Activa was designed for a long product life, with replaceable parts. Activa is quick and easy to assemble and disassemble, making refitting easy.

Maintenance information is available in the User's manual.

The chipboard meets the low emission E1 standard (EN13986) for formaldehyde.

Transport

Minimised packaging weight and packaging volume also help us improve filling rates and thus require less energy for shipping.

You require official certifications. We can deliver them.



Product Environmental Profile (PEP). Based on the ISO 14021, its purpose is to communicate precise, verifiable and accurate information on environmental aspects of the product during its life cycle.



Blauer Engel. Activa complies with the German environmental certification "Blauer Engel".



PEFC. The wooden components of Activa are labelled with PEFC (Programme for the Endorsement of Forest Certification).



E1. The particle board of Activa complies with the low emission E1 standard (EN13986).

You care about the end of use of your furniture.

We offer options - be it refurbishing, take-back, charitable donation or recycling.

Visit steelcase.com to discover more about Steelcase's unique ecodesign strategy.

Materials

Activa contains 26% recycled materials, by weight.

Like all the Steelcase products, Activa contains no hazardous materials such as PVC, Lead, Mercury, Cadmium, and Chromium VI or flame retardants.

The packaging contains at least 50% recycled materials and is printed with water-based inks i.e. without solvent.

Production

Activa is manufactured in our Rosenheim factory (Germany), which is ISO 14001/EMAS II certified like our other European sites in Sarrebourg, Wisches (France) and Madrid (Spain).

The powder coating is free of volatile organic compounds (VOC) and heavy metals.

The glue used to apply attach edges on the table is water based and releases no VOCs.

The wood wastes coming from the table-tops cutting are directly re-used to heat the production building. A filter avoids VOC emissions.

